



**SAFE
CORPORATION**

11, Clive Row, Room No. 11A,
Kolkata: 700001, West Bengal.

+91 9830515607 | +91 9831384631
91 - 33 - 2242 3713

✉ safecorp1@gmail.com

CHECK VALVES

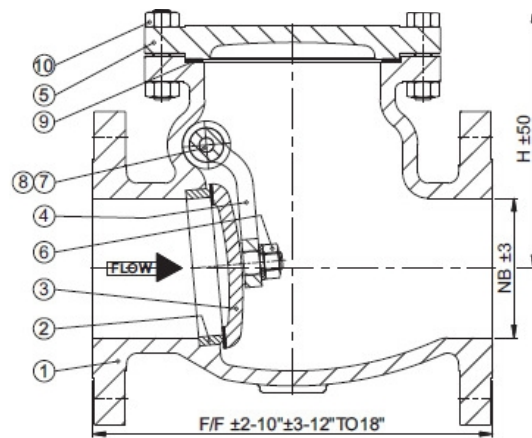

SR. No.	Part Name	Material	Qty.
1	Body	ASTM A 216 GR. WCB	1
2	Cover	ASTM A 216 GR. WCB	1
3	Disc	ASTM A 216 GR. WCB + 13% CR.	1
4	Seat Ring	M.S + 13% CR. / S.S.410	1
5	Hinge	AISI 410	1
6	Body Gasket	AISI 304 SPIRAL WOUND	1
7	Hinge Pin	MILD STEEL	1
8	Hinge Pin Bush	MILD STEEL	1
9	Cover Stud & Nut	ASTM A 193 B7/A 194 2H	REQ.
10	Nut & Washer	MILD STEEL	1 + 1

HYDRO TEST PRESSURE - Kg/Cm ²			
RATING	150#	300#	600#
SHELL	32	77	154
SEAT	22	56	112
AIR TEST PRESSURE - Kg/Cm ²			
SEAT	6	6	6

TECHNICAL DATA

Construction	: Swing Type Check Valve, Bolted Cover, Seat Ring
Design & Mfg Std	: As Per BS - 1868
Insp & Test Std	: As Per API 598/BS-6755-PT-1
Face To Face Dim.	: As Per ASME B16.10
End Connection	: Flange End As Per ASME B16.5 Class 150#
Moc	: WCB / CF8 / CF8M / CF3 / CF3M
Trims	: 13% CR. / S.S.304 / S.S.316 / S.S.304L / S.S.316L
Operation	: Handwheel / Gear / Actuator